

13p-DIN Roland GK-x-SIGNAL  
pins  
1 ..6 1 hi E ... 6 low E  
7 Gtr PU signal  
8 Synth (MIDI) Vol 0..5V DC  
9 unused  
10 S1 Pgm Down  
11 S2 Pgm Up  
12 + power (+7V)  
13 - power (-7V)  
case ground

Progr. Switch down/up (S1,S2)  
(not realized)  
purple:down  
gray:up  
(shield)

13 pin DIN female GK-compatible  
parallel to professional industrial plug by Binder (14p)

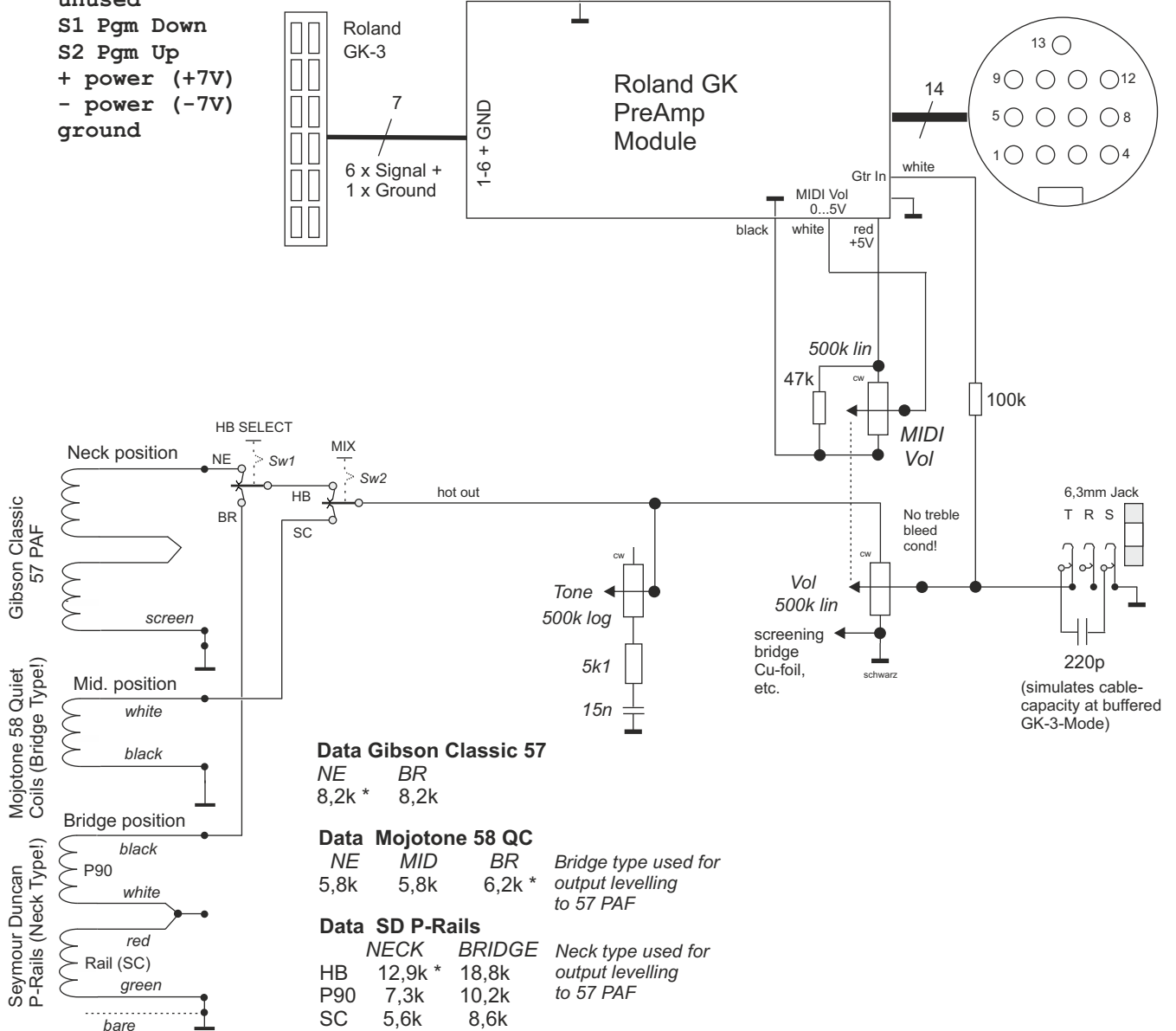

# WIRING Washburn HB36 with mixed PUPs and Roland GK-3 Kit

V 5 2017-03-25

Sigi Flamisch