

Phones Stereo Amp

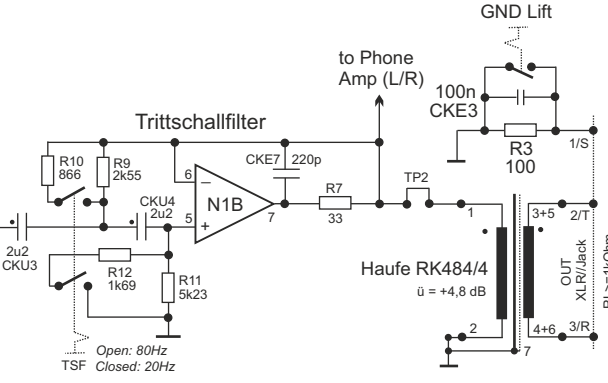

PCB 4xNetzteil (1x)

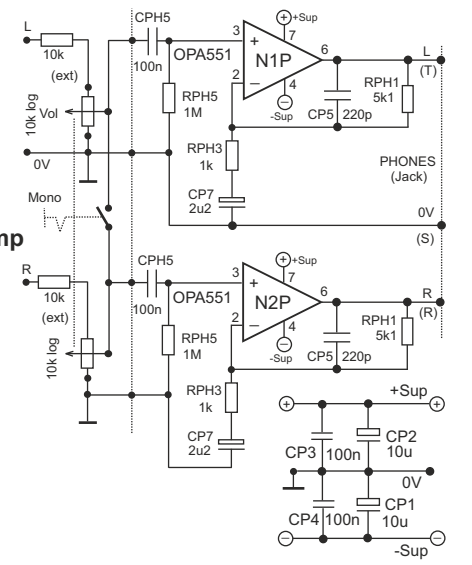
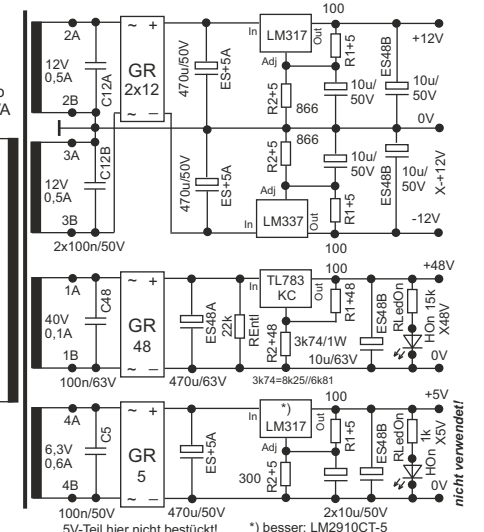

HI-END STEREO PREAMP V3

DI Siegfried Flamisch
V3.1 2022-01-14

- PCB: MicPreAmp3.brd (PreAmp x 2)
- PCB: xxx.brd (Pegelampel x 2)
- PCB: Mic-Sw2.brd (Headphone Amp 1x)
- PCB: 4xNetzteil.brd (1x)

